



SEMI-AUTOMATIC BALER

CK600HFPC

A MARKET LEADER IN
WASTE COMPACTION SOLUTIONS



International



ONE BALER, DIFFERENT WASTE STREAMS

The CK600HFEPC is one of the most versatile balers made by CK International. It can process a wide variety of materials including cardboard, paper, plastic film, PET bottles, hard plastics, E-Waste and other recyclables.

The CK600HFEPC comes with a Full Eject System (HFE) and a Portcullis Door (PC). It is used by waste recyclers, distribution and logistic centres, medium and large businesses with substantial volumes of waste.

With a 15kW motor and 60T compaction force, the CK600HFEPC produces bales of cardboard up to 600kg. A wide range of options are available to suit various recycling needs.

BENEFITS

- Full eject system for ease of use and to avoid cross-contamination
- Large feed-opening
- Strong and aggressive shear-blades will cut most materials
- Mill-size bale dimensions to optimise transport loads
- Automatic bale full system
- Cardboard, paper, soft plastics

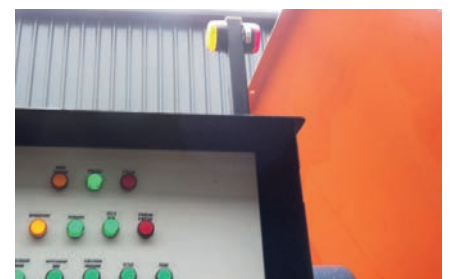

STANDARD FEATURES



AGGRESSIVE HEAD RAM

This consists of aggressive blades designed in a "V" shape to improve shearing when baling bulky or rigid materials.



RETENTION CLAWS

Retention claws are used for baling materials that tend to spring back, for example plastic films.

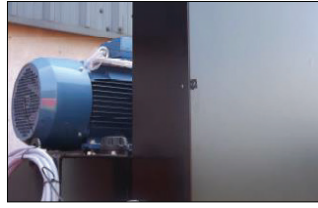

VANDAL PROOF DOOR

This can be added to prevent unauthorised usage of the machine and to prevent vandalism of the control panel.

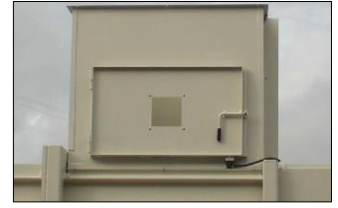

INTERLOCK ACCESS DOOR ON HOPPER

For easy access into the chamber should material become stuck.



DUAL PRESSURE SETTING

Enables the machine to change from high pressure to low pressure to bale both cardboard and plastic.

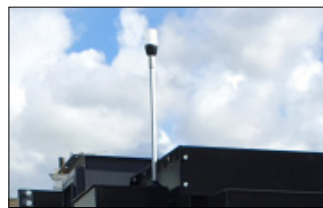

BEACONS

Start-up alarm included and flashing beacons will warn the operator when the machine is full or there is a jam.



POWER PACK COVER

Extra protection for the power pack against the elements.



ANTI-WHIP PROTECTION

Mechanical restraint used to prevent uncontrolled hose movement in the event of hose or coupling failure.

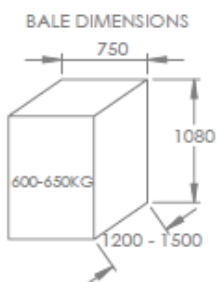
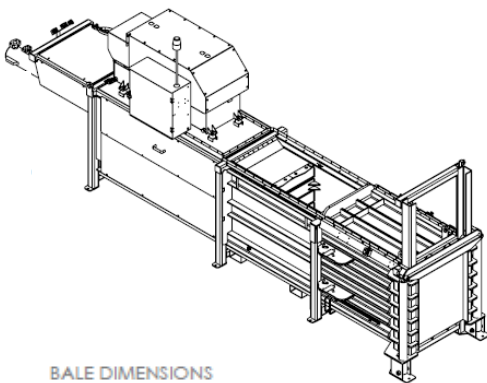
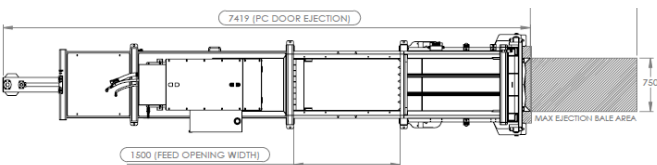

TECHNICAL DETAILS

BALER DIMENSIONS

Height (no hopper)	2365mm
Width	1410mm
Length	6350mm
Weight	Approx 7500kg
Feed Opening (L x W)	1500mm x 720mm

BALER PERFORMANCE

Compaction Force	60 tonnes
Cycle Time	50 sec / 34 sec
Motor	15kW / 22kW
Power Supply	3 x 415V, 50Hz
Noise Level	80dBA

BALE DIMENSIONS

Height	1100mm
Width	750mm
Length	1100mm
Bale Weight Cardboard (approx)	Up to 600kg
Bale Weight Plastic (approx)	Up to 550kg

CK600HFE.PC

5 x Steel Wires, Black Annealed	3.5mm dia., 4.6m long
Bale Ejection System	Full Eject
Tying Direction	Horizontal

CK International reserves the right to alter specification without prior notice. Bale weights given are guidelines only, actual bale weights depend on operator and material baled.

OPTIONAL EXTRAS

SIDE CONVEYOR



Left / Right Feed
1.2m wide

REAR CONVEYOR



0.7m wide

PERFORATOR



This should be used when
processing unperforated
PET bottles

GALVANISE



Ideal in food & drinks
industry where acidic
content can attack metal.

TRUNNION BIN LIFT



For trunnion style bins

COMB BIN LIFT



For comb style bins

OIL HEATER



If the temperature outside
is below 0°, we advise using
an oil heater.

OIL COOLER



If the temperature outside
is over 35° we advise using an
oil cooler.



CK INTERNATIONAL LTD

38a Eglis Road, Dungannon, Co. Tyrone, N. Ireland BT70 1LA | TEL: +44 (0)28 8775 3966
www.ckinternational.co.uk | info@ckinternational.co.uk